

NOTES:

- 1. COIL CFM: 60,000
- 2. ESTIMATED PLENUM WEIGHT: 25,500 LBS.
- 3. ROOF CURB SIZE (O.D.): 333"L X 186"W X 12"H
- 4. ESTIMATED INTERNAL SP: 2 25" WC
- 5. FLOOR OPENING SIZE: 80"L X 36"W

REVISION			
LTR.	DESCRIPTION	DRAWN	CHECKED

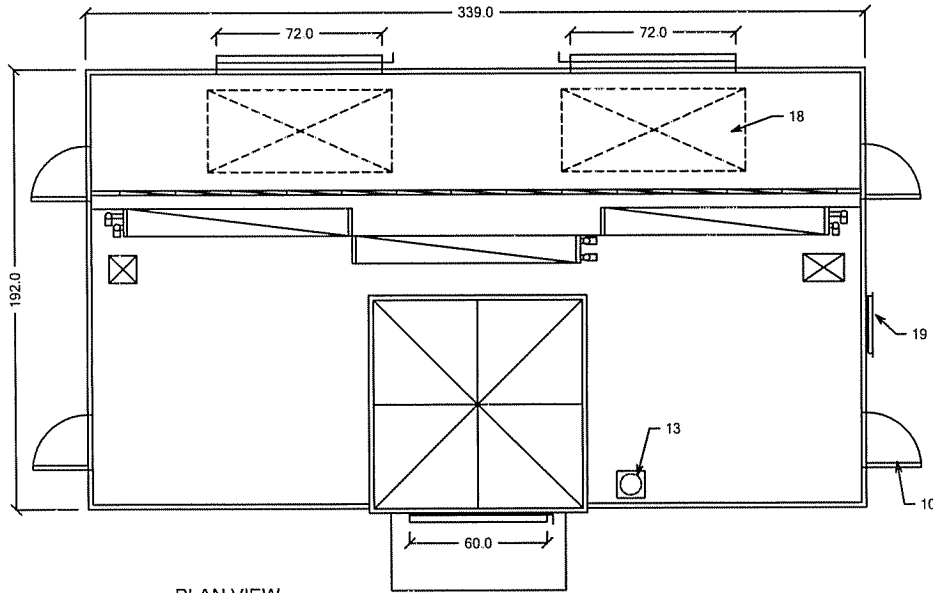

PLAN VIEW

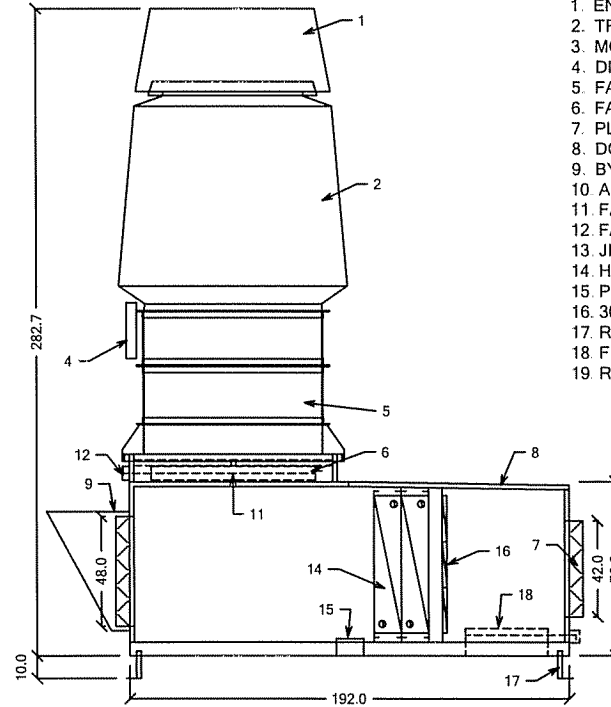

ELEVATION

DRAWING LEGEND:

- 1. ENTRAINMENT WINDBAND
- 2. TRI-STACK™ SILENCER NOZZLE (OPTIONAL)
- 3. MOTOR (NOT SHOWN)
- 4. DISCONNECT SWITCH
- 5. FAN HOUSING
- 6. FAN CURB W/ OPTIONAL VORTEX BREAKER
- 7. PLENUM ISOLATION DAMPER
- 8. DOUBLE-WALLED MIXING PLENUM
- 9. BYPASS DAMPER WITH RAINHOOD
- 10. ACCESS DOOR (TYPICAL)
- 11. FAN ISOLATION DAMPER
- 12. FAN ISOLATION DAMPER ACTUATOR
- 13. JIB CRANE SOCKET (OPTIONAL)
- 14. HEAT RECOVERY COIL
- 15. PIPE CHASE
- 16. 30% PREFILTERS
- 17. ROOF CURB (OPTIONAL)
- 18. FLOOR OPENING (OPTIONAL)
- 19. REMOVABLE PANEL

NOTE: BECAUSE WE ARE CONSTANTLY STRIVING TO IMPROVE OUR PRODUCTS, WE RESERVE THE RIGHT TO PROVIDE VERSIONS OF THESE PRODUCTS WITH SLIGHT VARIATIONS FROM THOSE ILLUSTRATED HERE.

© THIS DRAWING AND DESIGN IS THE EXCLUSIVE PROPERTY OF STROBIC AIR® CORP. AND IS COPYRIGHT. IT MUST NOT BE COPIED, OR USED FOR PRODUCTION, OR COMMUNICATED TO A THIRD PARTY, WITHOUT THE EXPRESSED WRITTEN PERMISSION OF THIS COMPANY.

UNLESS OTHERWISE SPECIFIED DIMENSIONS ARE IN INCHES TOLERANCES ARE - .XX ± .06" ± 1" - .XXX ± "	CONTRACT NO.		HEAT RECOVERY PLENUM MODEL # TS-5 60 HRU 1X1 1S 3-60X96		
	APPROVALS	DATE	STROBIC AIR® CORPORATION A SUBSIDIARY OF MET-PRO CORPORATION 160 CASSELL ROAD, BOX 144 HARLEYSVILLE, PA 19438		
	DRAWN E.W.H.	01/16/04			
	CHECKED				
MATERIAL	APRVD				
FINISH	U.S. PATENT NO. 6,431,974 U.S. PATENT NO. 6,112,850 U.S. PATENT NO. 4,806,706 CANADIAN PATENT NO. 1,277,171	SIZE B	CODE IDENT. NO.	DRAWING NO. TS-5 60 HRU 1X1 1S 3-60X96 R0	
		SCALE: N.T.S.	SHEET 1 OF 1		